

# CORNING

## No Polish SC Connector Jacket for 1.6 to 3.0 mm Cable

8802-T/1.6-3 8802-T/APC/FS/1.6-3 6802-T/50/1.6-3 6802-T/50/LOMMF/1.6-3 6802-T/62.5/1.6-3

P/N 78-0013-1184-0

Issue 3

[related literature](#) | [Search \[corning.com/opcomm\]\(https://corning.com/opcomm\)](#). Click on "Resources/Standard Recommended Procedures."

## INSTRUCTIONS

# 1.0 TABLE OF CONTENTS

1.0 Introduction .....	3
2.0 Connector Preparation .....	4
3.0 Cable and Fiber Preparation .....	4
4.0 Fiber Insertion .....	5
5.0 Splice Actuation .....	6
6.0 Boot Installation .....	6
7.0 Connector Re-termination .....	8

## SAFETY PRECAUTIONS

### Protective Eyewear

#### CAUTION!

To reduce the risk associated with eye injury:  
- Safety glasses should be worn when handling chemicals and cleaving the optical fiber.

### Chemical Precautions

#### WARNING!

To reduce the risk associated with fire:  
- Storage, use and disposal of isopropyl alcohol should be per your company health, safety and environmental instructions. Refer to material safety data sheet for health hazards, safe handling, proper use and control measures.

#### CAUTION!

To reduce the risk associated with eye or skin irritation from fiber gel in connector:  
- Product contains phenylmethyl silicone (63148-58-3), hydrophobic silica (68611-44-9) and may cause minimal eye irritation. Avoid contact with eyes and wash hands before eating or smoking. Upon eye contact, immediately flush eyes with water while holding eyelids open and continue flushing for ten minutes. Contact a physician. Upon skin contact, wash with soap and water.

### Bare Fiber Handling

#### CAUTION!

To reduce the risk associated with handling sharp glass fibers:  
- Cleaved glass fibers are sharp and can pierce the skin. Use tweezers when handling shards and dispose of them properly per your company health and safety instructions.

### Fiber/Cable Handling

#### NOTICE

To reduce the risk associated with fiber damage:  
- Optical fiber can be damaged by excessive tensile, compressive and bending forces. Consult the manufactures' specifications for proper handling instructions. Laser Safety

### Laser Safety

#### CAUTION!

To reduce the risk associated with eye damage from exposure to laser light:  
- Take the proper precautions when working with optical fiber because invisible laser light may be present. The principal laser hazard when working with fiber optics is injury to the eye. Never look directly into the fiber or connector using the naked eye or a microscope.

# 1.0 INTRODUCTION

**1.1** No Polish SC Jacket Connectors enable fast, on-site installation of 1.6 mm to 3.0 mm kink resistant cable\* along with 1.6 mm by 2 mm, and 2 mm by 3 mm rectangular drop cable with G.657 bend insensitive fiber. The SC/APC and SC/UPC compatible connectors consist of a factory-polished ferrule assembly and a flat cleave, mechanical splice. A twist on, hard shell boot clamps onto the cable jacket and aramid fiber to provide excellent strain relief.

\*Using G.657 bend insensitive fiber and a thick wall jacket that is filled with aramid fiber, kink resistant cable can be bent at a 90 degree angle across a sharp corner without excessive insertion loss.

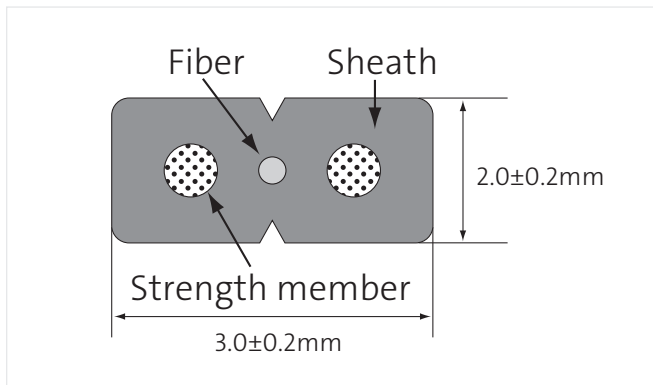

Required tools, which are available in the No Polish Connector Kit with Cleaver 8865-C

1. 8865-AT No Polish SC Connector Assembly Tool 250/900 μm
2. 8835-AT No Polish LC Connector Assembly Tool 250/900 μm
3. 8845-AT No Polish ST Connector Assembly Tool 250/900 μm
4. 2534 Fiber Cleaver (not included in 8865 kit)
5. 6365-ST Stripping Tool
6. 6365-KS Aramid Yarn Snips
7. Lint-Free Cloths (100/pkg)

Reagent Grade Isopropyl Alcohol is required, but not supplied.

As an option, the No Polish Connector Assembly Tool Jacket 8865-JT can be used to assist in installation, which is available separately.

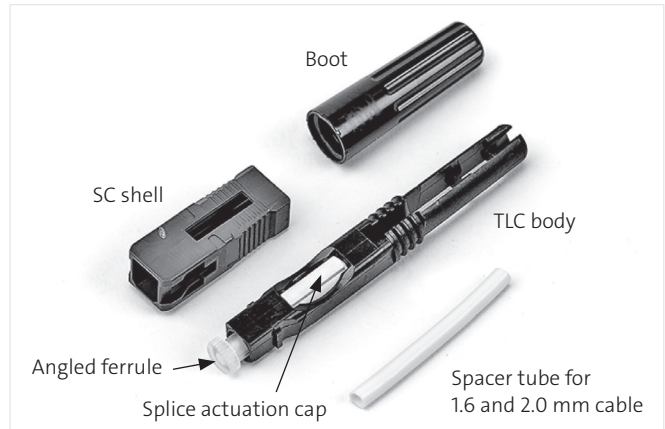

No Polish SC/APC Flat Splice Connector Jacket  
8802-T/APC/FS/1.6-3

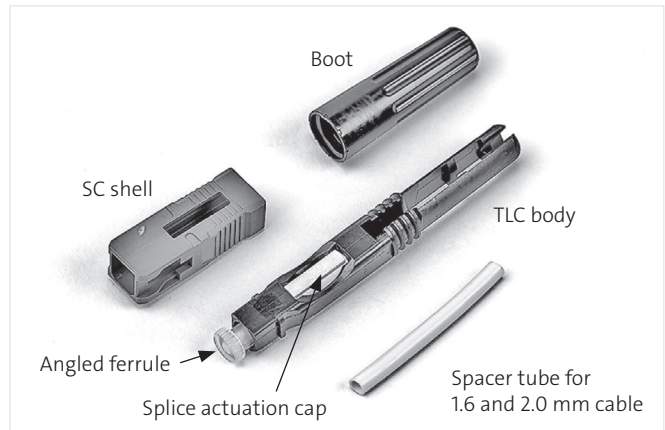

No Polish SM SC/PC Connector Jacket  
8802-T/1.6-3



No Polish Connector Kit with Cleaver  
8865-C

## 2.0 CONNECTOR PREPARATION

**2.1** Carefully remove connector parts from the bag.

**2.2** Ensure the actuation cap is not pushed in before installation. Cap should be level with the connector body. If the cap is pushed in, complete steps 7.1 and 7.2 to lift the cap.

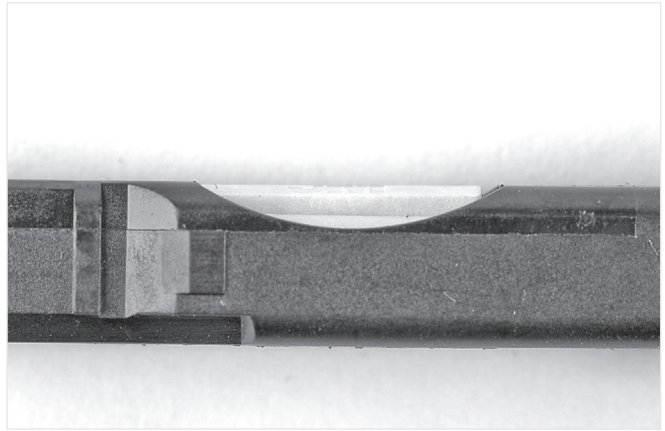

## 3.0 CABLE AND FIBER PREPARATION

**3.1** Slide boot onto the cable with the boot's threaded opening nearest the cable end. If using 1.6 or 2.0 mm cable or 1.6 mm x 2.0 mm rectangular drop cable, slide the flexible spacer tube over the cable.

**3.2** Remove at least 55 mm (2.2 inches) of cable jacket using the fiber stripper.

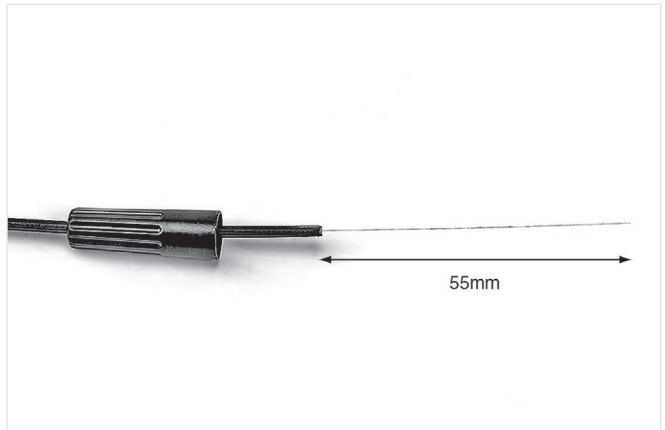
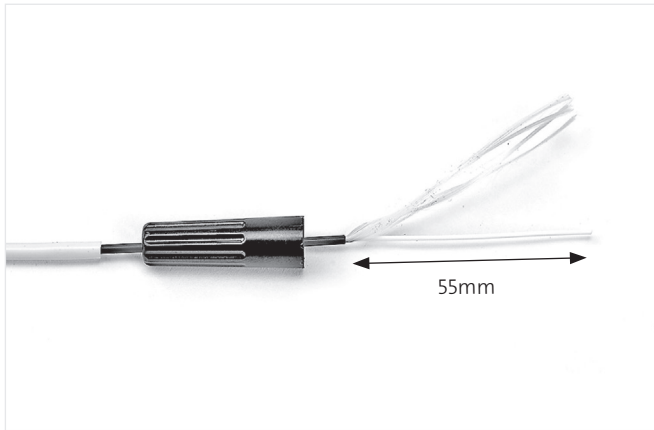
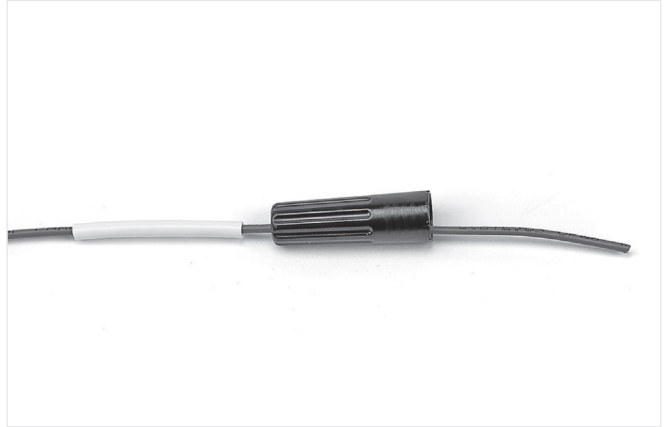

**3.3** Measure 26 mm  $+0/-1$  mm (1.02 in.  $+0.0/-0.04$  in.) from jacket end and mark with pen on buffer.

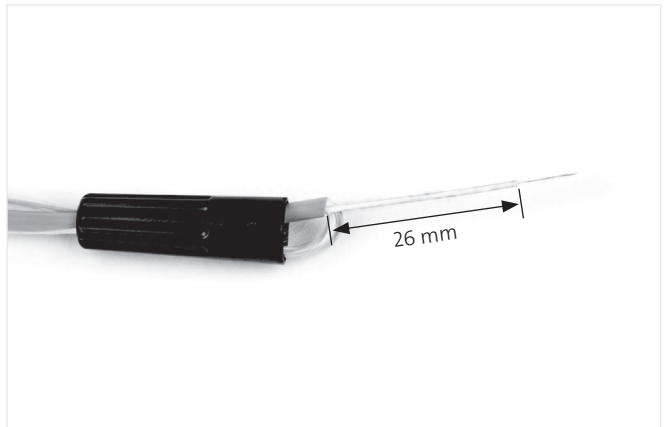

**3.4** Strip the 900  $\mu\text{m}$  and 250  $\mu\text{m}$  coating from the end of the 26 mm mark to the fiber end. If the fiber has a semi-tight 900  $\mu\text{m}$  coating that can be removed separately, then strip the 900  $\mu\text{m}$  from the outer jacket while leaving the 250  $\mu\text{m}$  coating on the fiber.

**3.5** Clean fiber with alcohol and lint free cloth.

**3.6** Cleave fiber to 8 +/-0.5 mm.

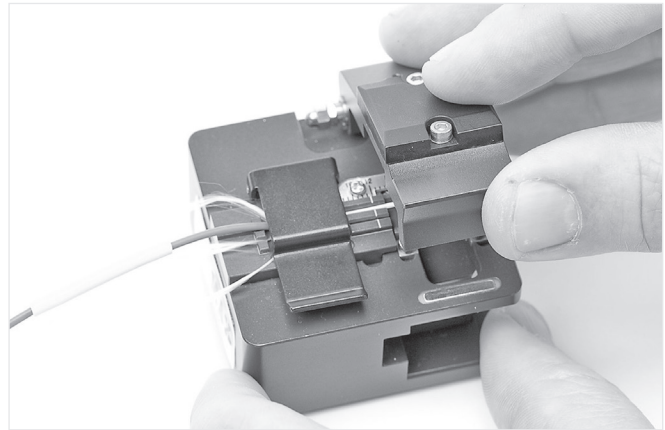
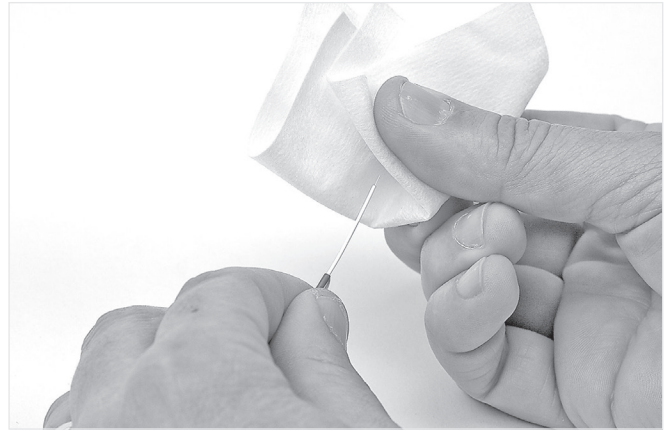

## 4.0 FIBER INSERTION

**4.1** Keep the aramid yarn pulled away from the cleaved fiber and VERY SLOWLY insert the optical fiber into the connector body. Attempt to insert fiber end into bore without touching any surface.

For rectangular drop cable, insert fiber so the widest section of the cable will be clamped.

**Note:** *If the cleaved end is contacted, it can be contaminated. If this occurs, the fiber needs to be prepared again with another strip, clean and cleave as shown in section 3.*

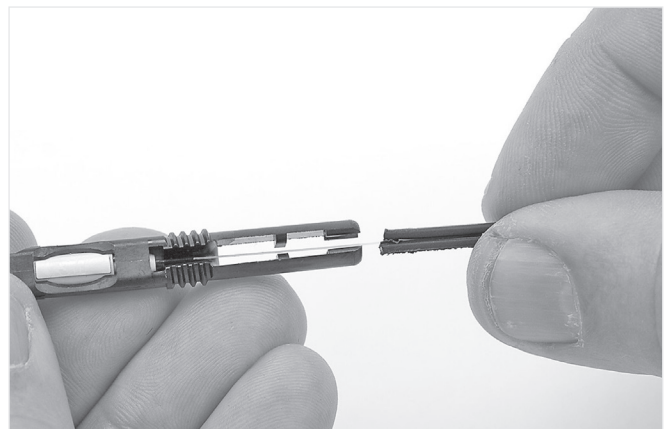
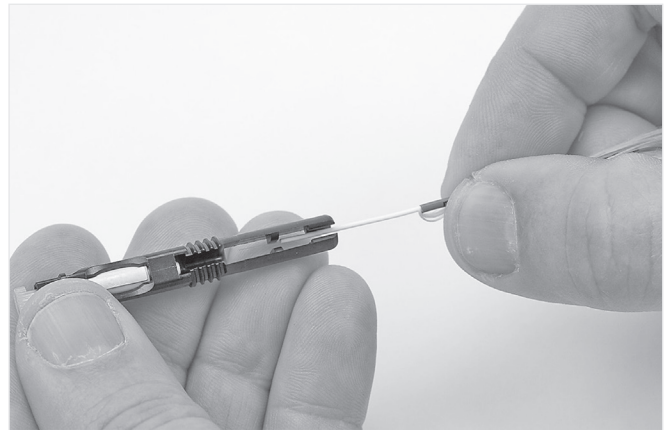

**4.2** Create bow in fiber.

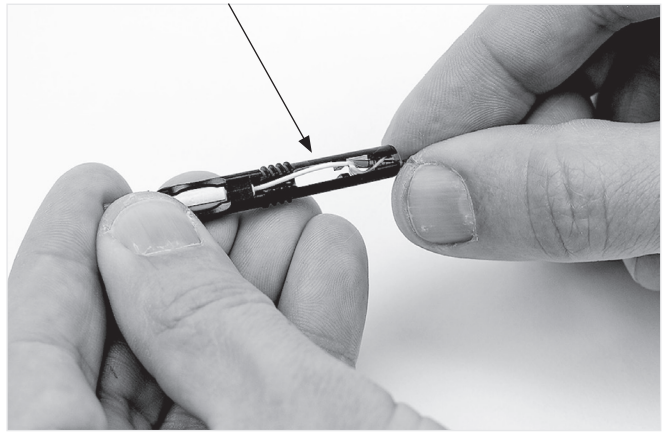
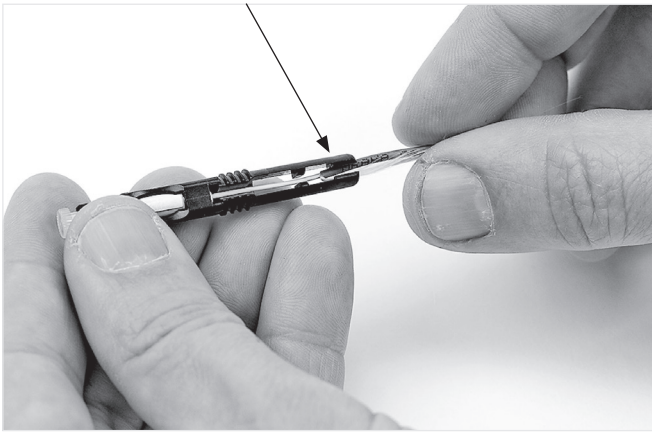

## 5.0 SPLICE ACTUATION

**5.1** Hold connector body and cable to maintain the fiber bow. Press the center of the actuation cap with your finger. Confirm the cap is actuated completely.

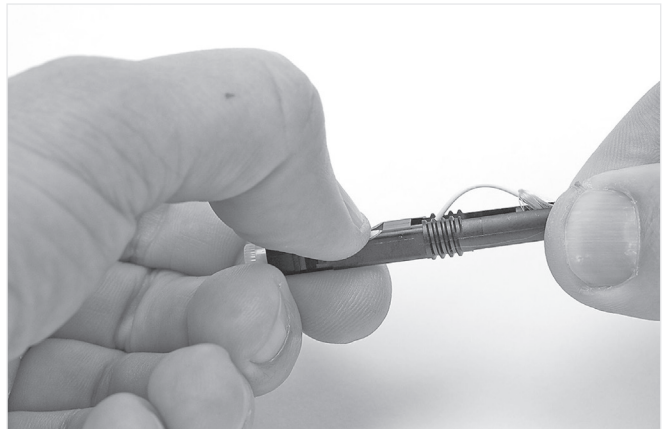

## 6.0 BOOT INSTALLATION

**6.1** Pull the aramid yarn so it exits the bottom of the connector, as shown.



**6.2** Make sure the fiber is not bowed. If using 1.6 or 2.0 mm jacket or 1.6 mm x 2.0 mm rectangular drop cable, slide spacer tube to end of fork on connector body, as shown.



**6.3** Hold aramid yarn straight in bundle on underside of connector as shown in photo. Lightly pull jacketed cable ensuring bow is fully removed. Aramid yarn should be straight but not tensioned. While advancing boot to thread, observe that buffer does not bow. Twist boot two full rotations to partially anchor aramid yarn.



**6.4** Twist aramid yarn to boot and allow some slack as shown.



**6.5** While observing buffer through window, twist boot final two turns. Buffer should not show any bow through window. Fully tighten boot for maximum pull strength.

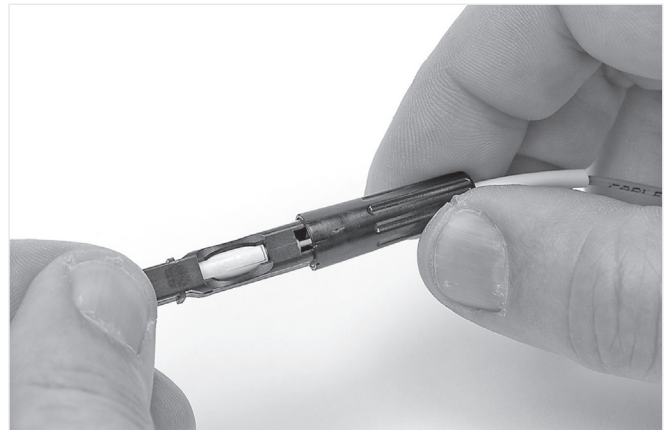

**6.6** If pre-test is desired, do so prior to trimming aramid yarn. This will allow deactivation and repositioning of cleave and/or removal of fiber bow if necessary. Trim aramid yarn even with boot.

**6.7** Per photo, slide shell over connector body so the hole in the shell matches the actuation cap on top of the connector. A click should be heard when complete.

**6.8** If connector is to be installed, remove dust cover and clean connector end face with isopropyl alcohol and a lint free cloth.

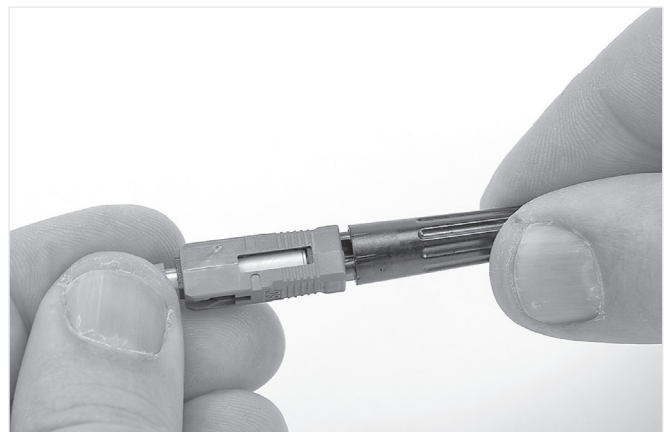

## 7.0 CONNECTOR RE-TERMINATION

**7.1** If the aramid yarn has not been trimmed, Steps 6.1-6.7 may be repeated to remove a micro-bend loss.

To completely re-terminate the connector one additional time:

**7.2** Insert the cap lifter into the bottom of the connector.

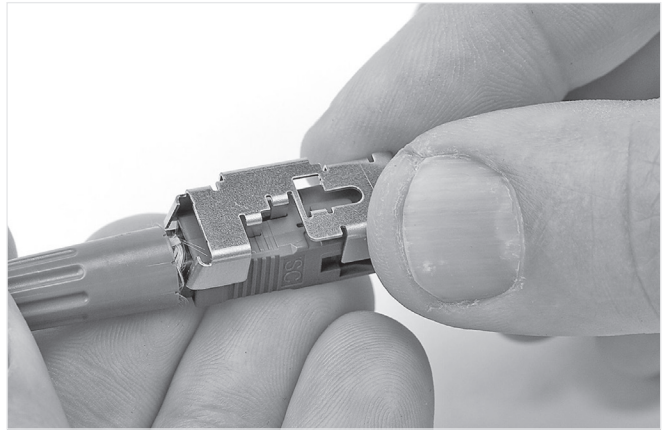

**7.3** Push cap lifter until it is fully inserted into the connector.

**Note:** Connector shell position may need to be adjusted so the cap lifter prongs can mate with slots inside the connector body.

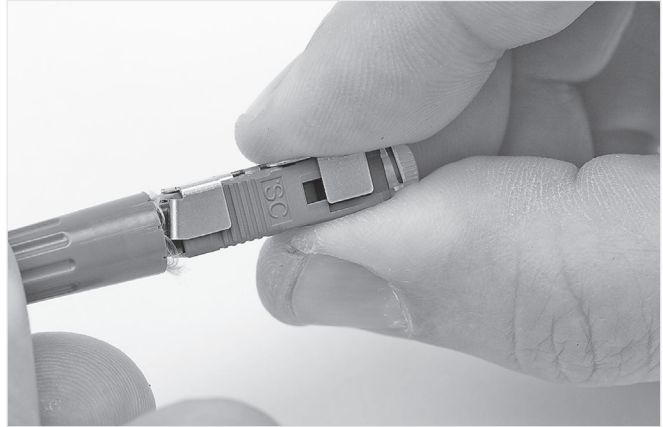

**7.4** Unscrew the boot from the connector body and remove fiber from the connector body.

**7.5** Repeat Steps 3.2 through 4.2.

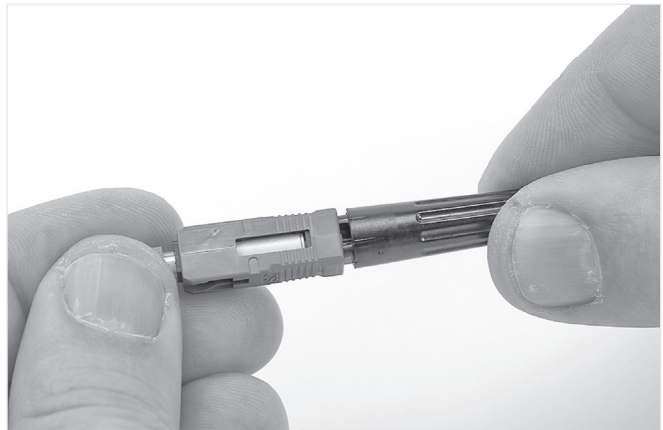

**7.6** While maintaining the fiber bow, press the actuation cap using the side of the cap lifter until the cap is fully depressed.

**7.7** Repeat section 6.

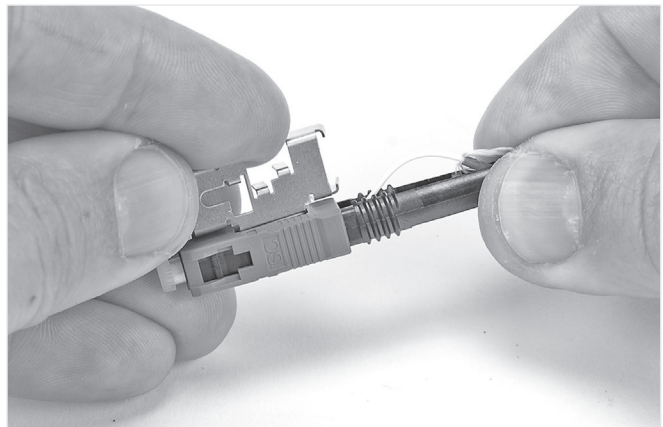

## NO POLISH SC JACKET CONNECTOR ORDERING INFORMATION

Product Number	Description	ID
6802-T/50/1.6-3	No Polish SC Jacket Connector MM 50 um for 1.6-3.0 mm jacketed cable	80-6113-9828-2
6802-T/50/LOMMF/1.6-3	No Polish SC Jacket Connector LOMMF 50 um for 1.6-3.0 mm jacketed cable	80-6113-9829-0
6802-T/62.5/1.6-3	No Polish SC Jacket Connector MM 62.5 um for 1.6-3.0 mm jacketed cable	80-6113-9830-8
8802-T/1.6-3	No Polish SC Jacket Connector SM for 1.6-3.0 mm jacketed cable	80-6113-3507-8
8802-T/APC/FS/1.6-3	No Polish SC/APC Jacket Connector SM for 1.6-3.0 mm jacketed cable	80-6113-3509-4

**NOTES:**

**NOTES:**

---

Corning Optical Communications LLC • 4200 Corning Place • Charlotte, NC 28216 USA  
800-743-2675 • FAX: 828-325-5060 • International: +1-828-901-5000 • [www.corning.com/opcomm](http://www.corning.com/opcomm)

Corning Optical Communications reserves the right to improve, enhance, and modify the features and specifications of Corning Optical Communications products without prior notification. A complete listing of the trademarks of Corning Optical Communications is available at [www.corning.com/opcomm/trademarks](http://www.corning.com/opcomm/trademarks). All other trademarks are the properties of their respective owners. Corning Optical Communications is ISO 9001 certified. © 2019 Corning Optical Communications. All rights reserved.